

# What hearing instrument users need to know about their batteries<sup>1</sup>

By Louis Du Brey Au.D.  
Basin Audiology



## **What is a zinc air battery?**

Zinc air is the most popular battery power system for hearing aids. Through a unique construction that utilizes air from outside the battery, these batteries produce much more energy than any other battery system due to a much higher energy density. With zinc air batteries, you can expect much longer battery life than any other batteries of the same size.

## **What are the common battery sizes?**

The most common battery sizes are 10, 312, 13, 675 and 675 Cochlear Implant. As hearing instruments get smaller, the size 10 is becoming more common. For the most part, the size of the battery is dictated by the size of the hearing aid—smaller hearing aids use smaller batteries. To identify the size, manufacturers use industry standard color and numeric codes on their zinc air tabs and packaging as follows:

- **Color Coding System**

- Size 10 (*yellow*)
- Size 312 (*brown*)
- Size 13 (*orange*)
- Size 675 or 675 Cochlear Implant (*blue*)

## **How long will my batteries last?**

Battery life is determined by the following:

- Size of the battery—smaller batteries have shorter life.
- Type of amplification and processor in your hearing aid.
- The number of hours you wear your hearing aid.

With the smallest batteries, life will be as short as 3-5 days, while the battery life of the larger batteries can be 21+ days. Batteries are relatively inexpensive. A one year supply of batteries for the smallest hearing aid might average \$65.00 per year. A larger hearing aid using a larger battery, #13, might cost \$25.00 per year.

## **What is a high power zinc air battery?**

Some batteries claim to be high power. These batteries can amplify signals loudly with less distortion by

<sup>1</sup>

Original text for this document provided via e-mail correspondence with Jane Oh at iCellTech Corporation as a courtesy to Basin Audiology. Original document titled: *Q & A Updated on October 13, 2006. Basin Audiology no longer sells iCell batteries.*

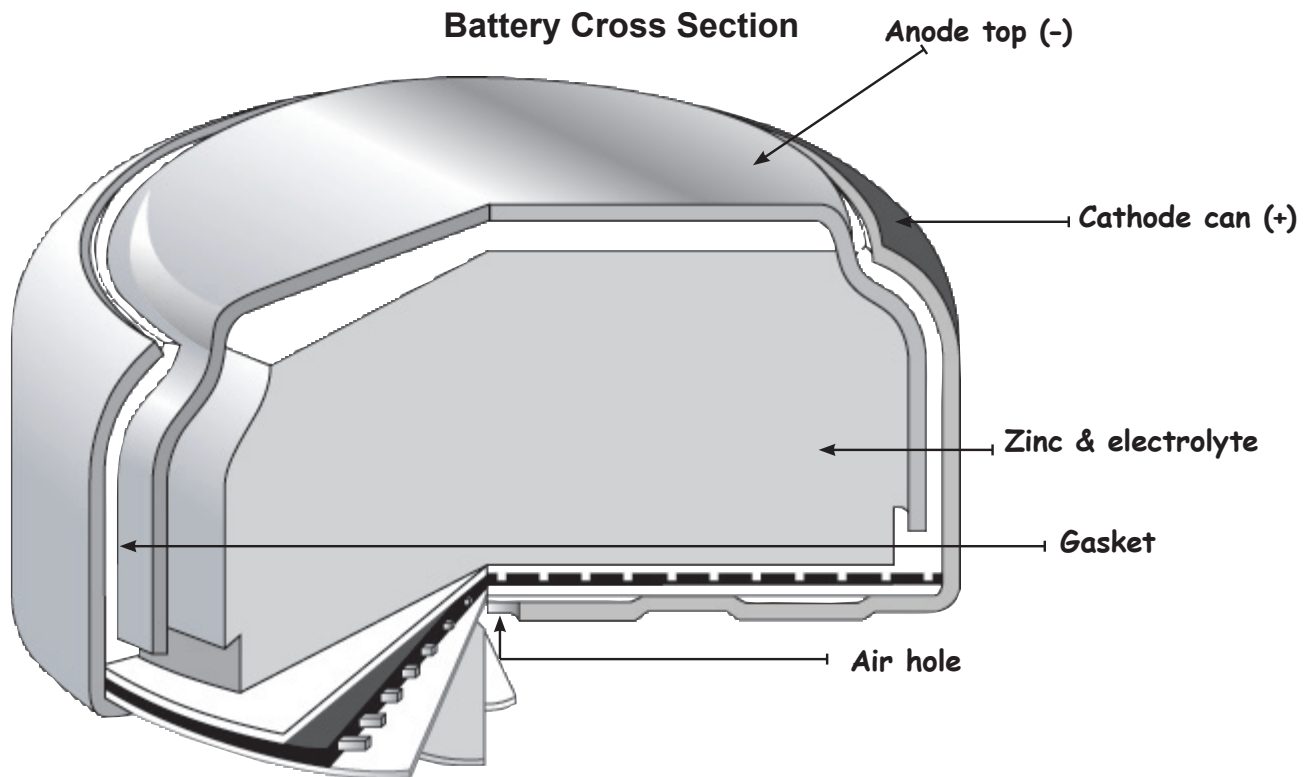

providing adequate current drain, which is required by some hearing aid devices. We use the professional series which are the highest quality level with longest running time.

### **Why is there a tab on my zinc air battery?**

A zinc air battery uses air outside the battery as a source of power. The factory applies a tab which seals the air holes on the battery to ensure freshness and prevent self-discharge until you are ready to use the battery. **Do not remove the tab until you use the battery.**

### **How should I store my batteries?**

You should store your hearing aid batteries at room temperature. Avoid storing your batteries in hot places or in sunlight. Heat will shorten the life of batteries. Do not store batteries in the fridge as it affects battery performance and capacity. The batteries shouldn't be exposed to excessive moisture or dryness. Batteries should not be carried loose in your pocket or purse with other metal objects such as coins or keys. It's recommended that batteries be carried in the package that you bought them in. **Carrying loose batteries allows them to short-circuit.** Store and discard batteries in places where they cannot be

reached by children and animals, and away from your medications. If a battery is swallowed, see a doctor immediately. For more information on what to do if a battery is swallowed, see our article [here](#).

### **Can a battery tester tell how long a battery is going to last?**

Many people think that a battery tester will tell you how long a battery would run. It is not true for zinc air batteries. The battery tester for alkaline batteries can tell you how long a battery lasts because the discharge curve of an alkaline battery is very steep. However, zinc air batteries have a very flat discharge curve. Zinc air discharges for a long time at flat voltage and then expires suddenly. As a result, the ending date cannot be anticipated by using a battery tester. Battery testers only tell you if the battery is good or already discharged. Each hearing aid battery has its own characteristics per manufacturer. A battery could have low voltage measured with the tab on, or right after the tab is taken off. It would be a mistake to judge the battery dead when it is tested under these conditions. Once again, low initial voltage has nothing to do with the performance of the batteries as the voltage builds up high enough to perform to full capacity after enough activation time. **Caution:** some cheap testers, especially with a lamp, require very

high current drain to measure. If you use these testers, battery life could be reduced significantly following measurement.

### **Nominal voltage (1.4 volts) vs. operating voltage?**

1.4 volts is a zinc air battery's nominal voltage when measured after fully activated without any load and it can be slightly different per manufacturer. However, the battery's actual operating voltage is less than that, approximately 1.2 or 1.25 volts, when measured with load. Hearing instruments work very well as long as the battery maintains its operating voltage above 1.1 volts.

### **Why is voltage low on a new battery?**

Zinc air battery activation starts immediately after removal of the tab. Voltage measured at that time is lower than the specified voltage of 1.4 volts. This has nothing to do with battery capacity and you should not worry. It will be fully activated within a minute. You should not insert the battery into your hearing aid for at least one minute after removing the tab to allow for proper activation time. Hearing instruments will amplify properly only if the working voltage is over 1.1 volt. Low voltage before activation means the tabs are sealing the air holes and protecting the batteries from self-discharging—it's a good thing.

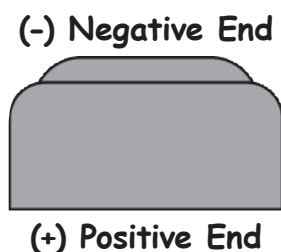

### **How should I store my battery overnight?**

Do not store hearing instruments overnight with the battery door closed. It will cause howling and make a continuous BEEP sound or acoustic feedback. This will shorten the battery and hearing aid life significantly. Opening the door will switch the hearing instrument off and also provide a larger opening to remove moisture overnight.

### **Do hearing aid dryers affect my battery?**

Hearing aid dryers are either passive or active. Passive dryers use a container with silica crystals to

dehydrate your hearing instruments overnight. These are the same crystals you find in small packages inside your vitamins bottles and some new electronics. Active dryers differ from passive because they use electricity to heat and dehydrate hearing aid moisture. Dryers are good for all hearing aid users, but active systems evaporate more moisture in less time. Regardless of your dryer type, **it's not important to remove the battery from the hearing aid.** Just make sure battery door stays open while in the dryer.

### **What should I do if my hearing aid doesn't work with a new battery?**

The following are the main causes of hearing aid failure related to battery problems:

- Not enough time for battery activation after removing the tab—wait at least one minute.
- Check for a dented battery surface. Dents cause poor contact with the battery terminal of the hearing instrument.
- Possibly a dead battery, but this occurs rarely with a new battery.
- Check for debris on the battery terminals of the hearing aid.
- Check that the battery fits into the battery holder or door of the hearing aid. Some battery holders are designed with a smaller cavity where the negative or tapered end of the battery is placed.

If your hearing instrument doesn't work properly after inserting a new battery, please call the office.

### **What is the difference between 675DS and a 675 cochlear implant, CI, battery?**

Both have blue tabs and can be used in hearing aids using size 675 batteries. A 675DS is suitable in BTE hearing aids and provides the longest running time. However, since it does not provide very high current, it is NOT a good choice for cochlear implants and overall life will be significantly reduced. A CI battery provides high current so that the implant operates properly and for a longer period of time between battery changes. A CI battery can be used in BTE hearing aids, but the running time would be reduced by 20%.